

ASSEMBLY INSTRUCTIONS FOR

Metro Deep Ledge Utility Carts (#12700B & 12701B)

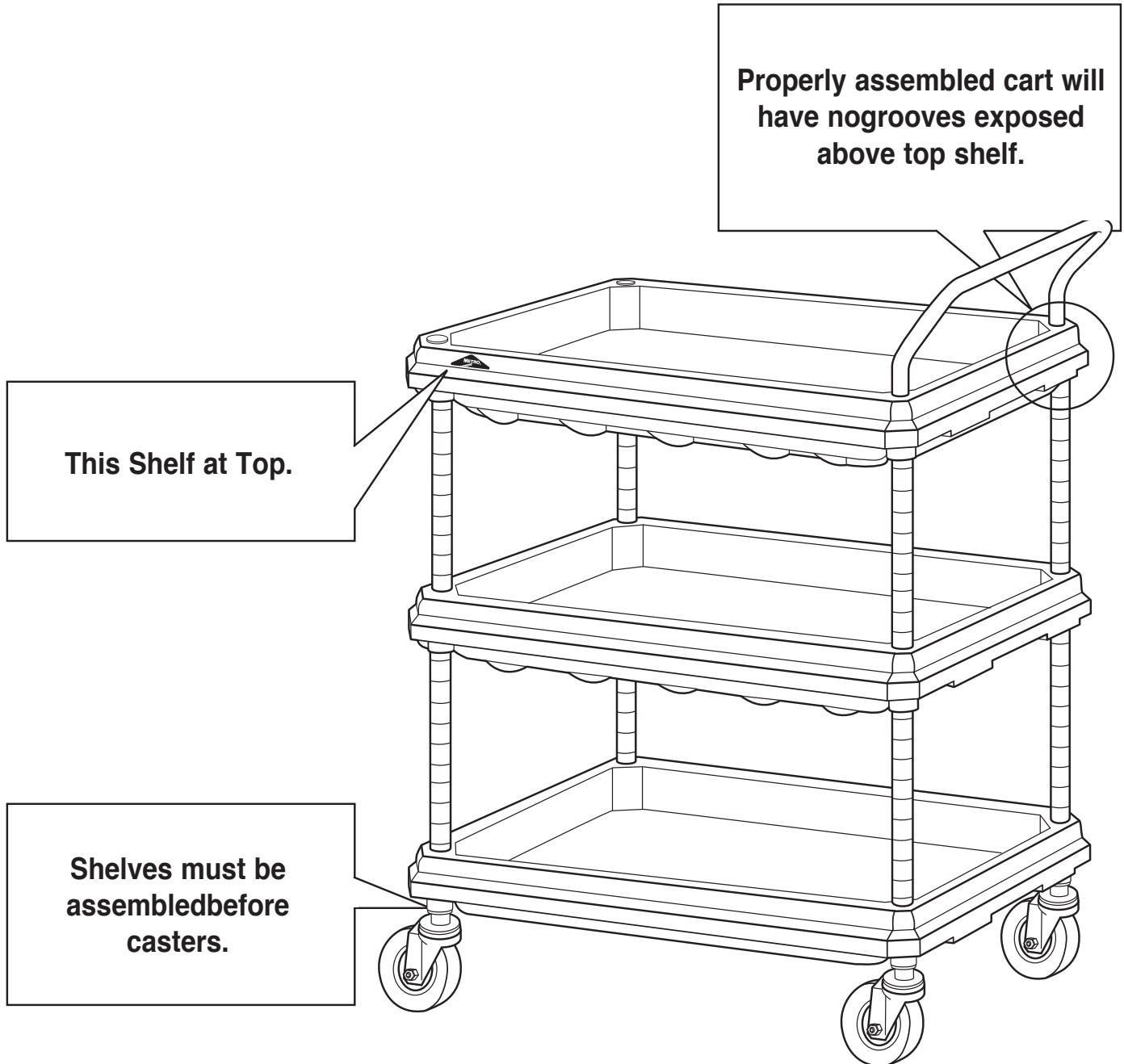

Call Free 1.800.848.1633 • Fax Free 1.800.447.2923

Web: GoHCL.com • Email: hcl@GoHCL.com

ASSEMBLY INSTRUCTIONS FOR

Metro Deep Ledge Utility Carts (#12700B & 12701B)

LIST OF COMPONENTS

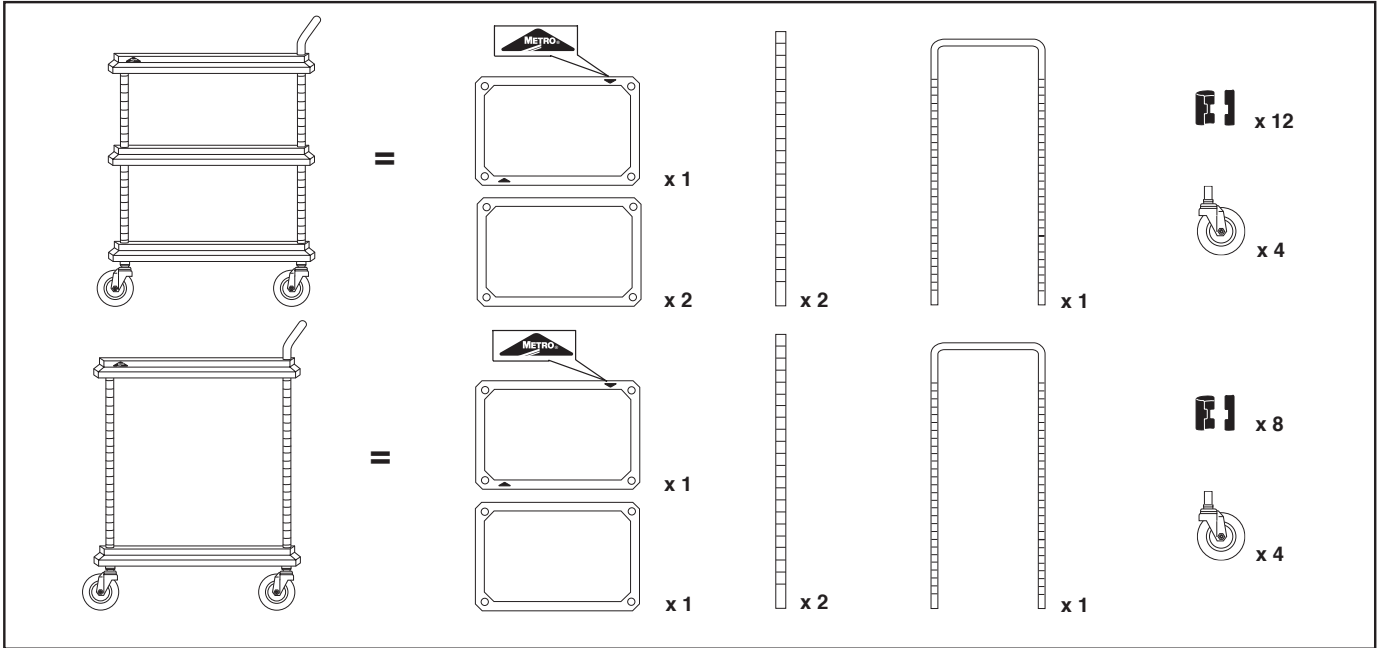

ATTENTION! Shelves must be assembled before casters.

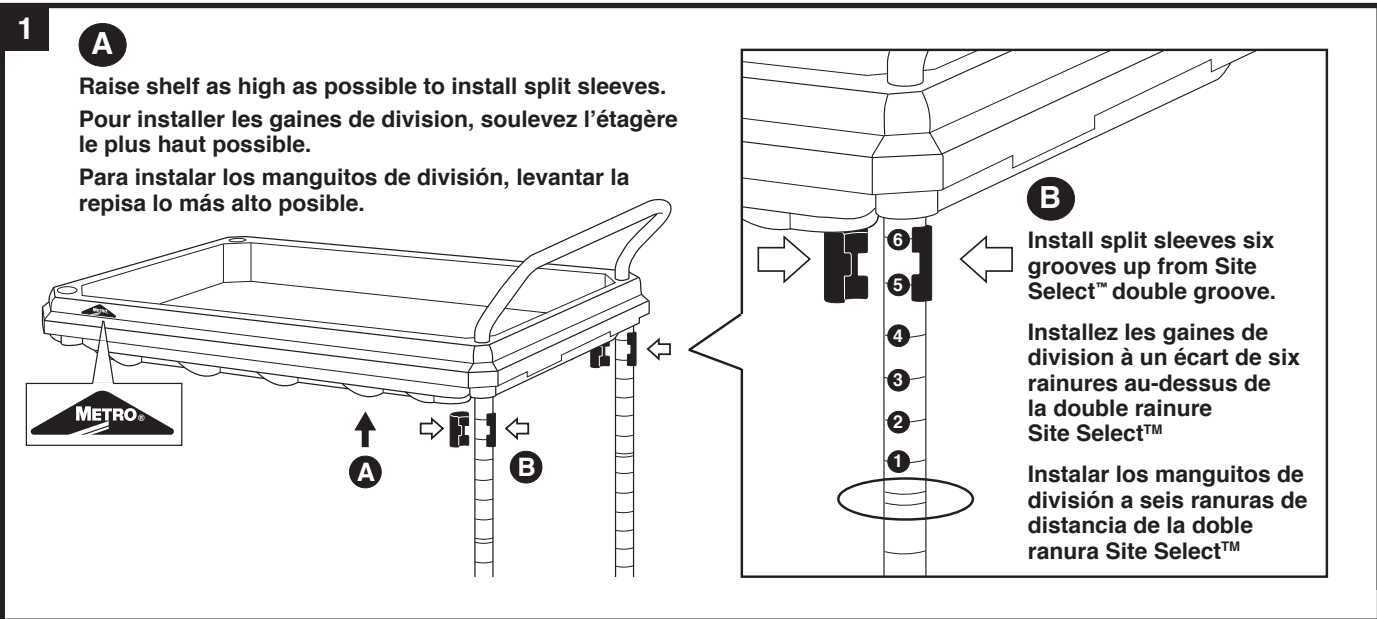

Call Free 1.800.848.1633 • Fax Free 1.800.447.2923
 Web: GoHCL.com • Email: hcl@GoHCL.com

ASSEMBLY INSTRUCTIONS FOR

Metro Deep Ledge Utility Carts (#12700B & 12701B)

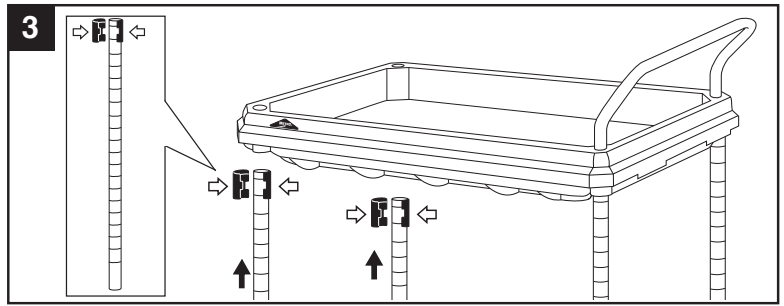
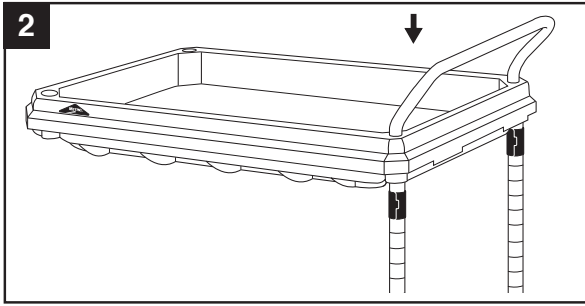

For 3-shelf unit, install middle shelf now. **4**

For 2-shelf unit, proceed to step **6**.

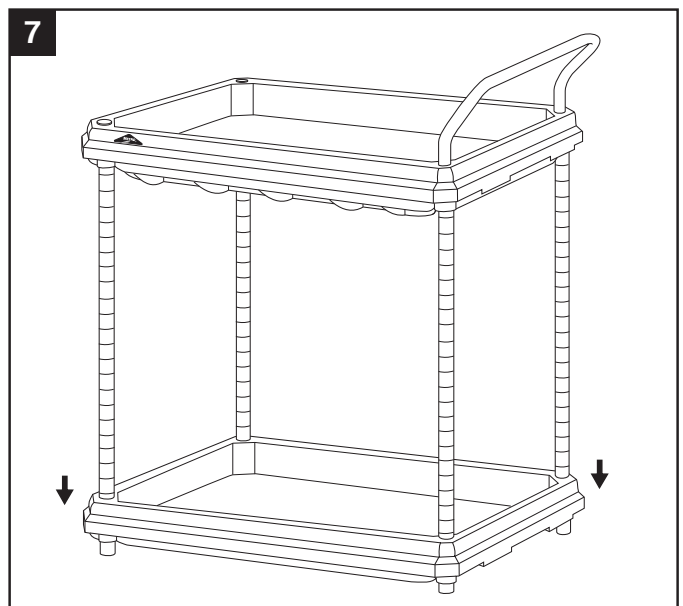
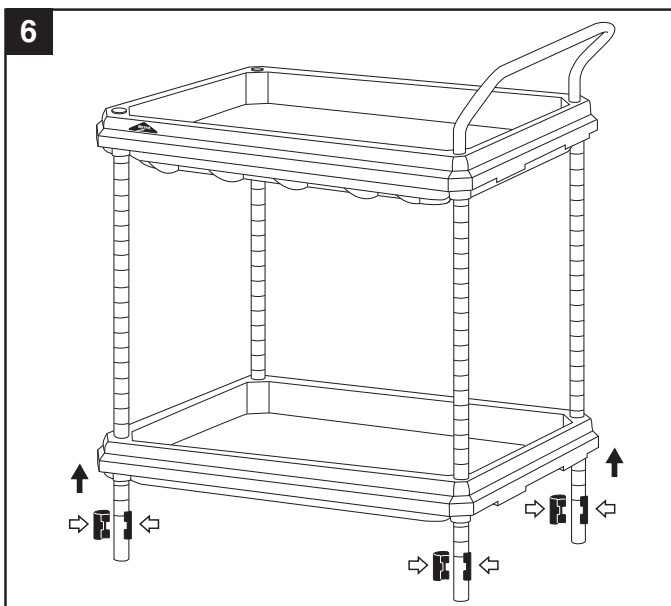
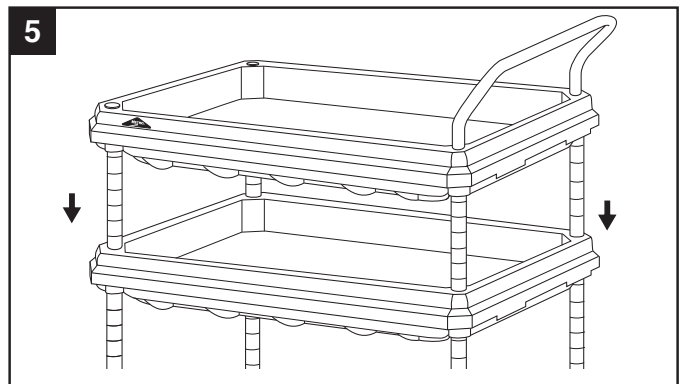
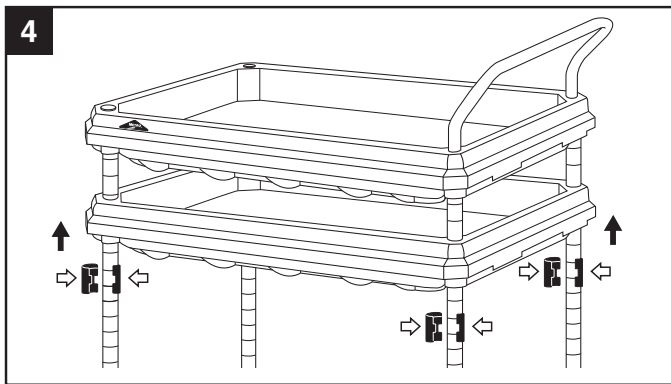

Call Free 1.800.848.1633 • Fax Free 1.800.447.2923
Web: GoHCL.com • Email: hcl@GoHCL.com

ASSEMBLY INSTRUCTIONS FOR

Metro Deep Ledge Utility Carts (#12700B & 12701B)

8

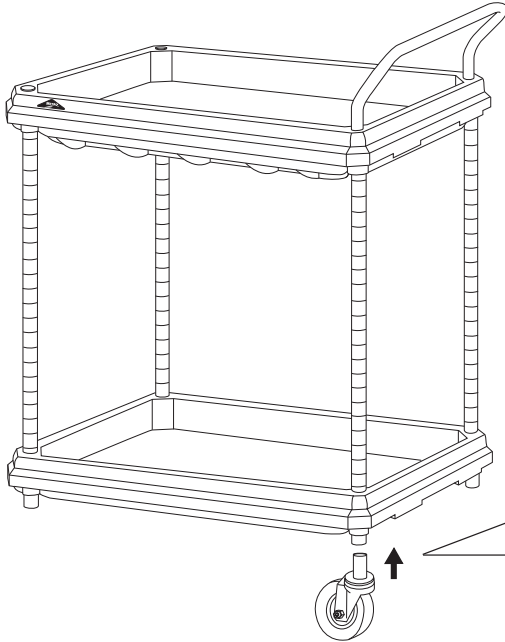

ATTENTION! Shelves must be assembled before casters.

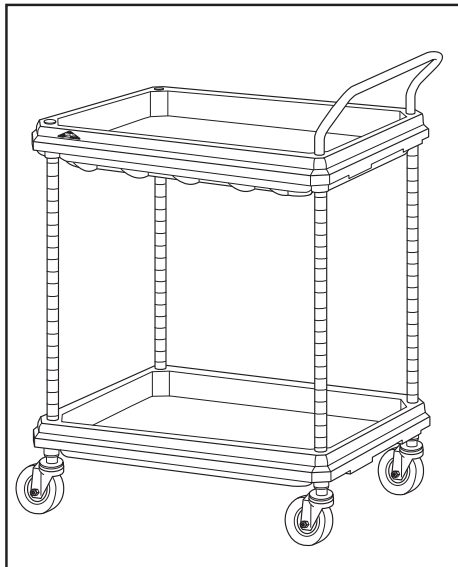
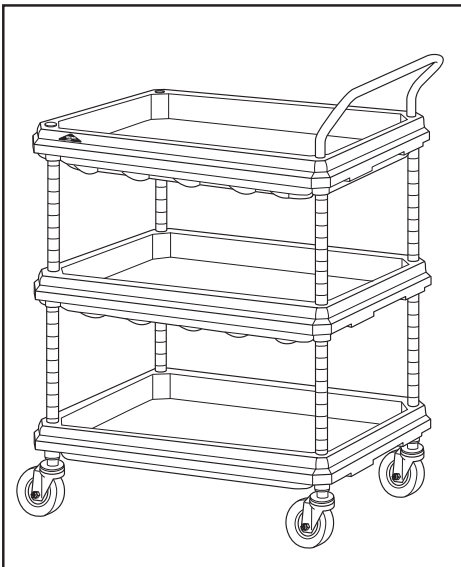
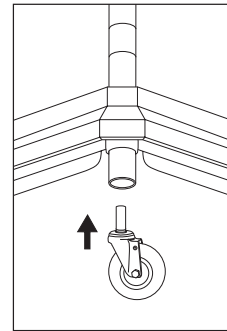

WEIGHT LOAD CAPACITY

Shelf	150 lbs. (68 kg)
Unit	400 lbs. (182 kg)

Call Free 1.800.848.1633 • Fax Free 1.800.447.2923

Web: GoHCL.com • Email: hcl@GoHCL.com